



Series 6690 : Mobile Fuel Monitoring System

For Construction / Mining / Transportation Industry
Installation on Excavators / Tipper / Cranes / Hyva / Loaders / Dumpers



Fuel Flow Sensor



Data Collector Unit (DCU)



Data Transmission Unit (DTU)

Introduction

The Series 6690 Fuel Monitoring System is a unique innovative product specially designed to provide accurate highly reliable information on complete fuel management of diesel driven machinery. The system offers an excellent solution to issue as fuel misuse, pilferage, low utilization of machines and low operating efficiency of diesel driven machinery.

Features

- Accurately measures and logs fuel consumed
- Measures and logs engine Run Hrs.
- Measures distance traveled in kms.
- Accurate measures and logs fuel filled and tank balance.
- Data logging is done in real time.
- Manual data transfer to PC.
- Wireless data transfer to server on GSM network optional.
- Ruggedised for use with high vibrations and shock load conditions.
- 12 V DC operation on engine cranking battery.
- PC software utility with data base connectivity.
- Non editable file storage in database.

Installation

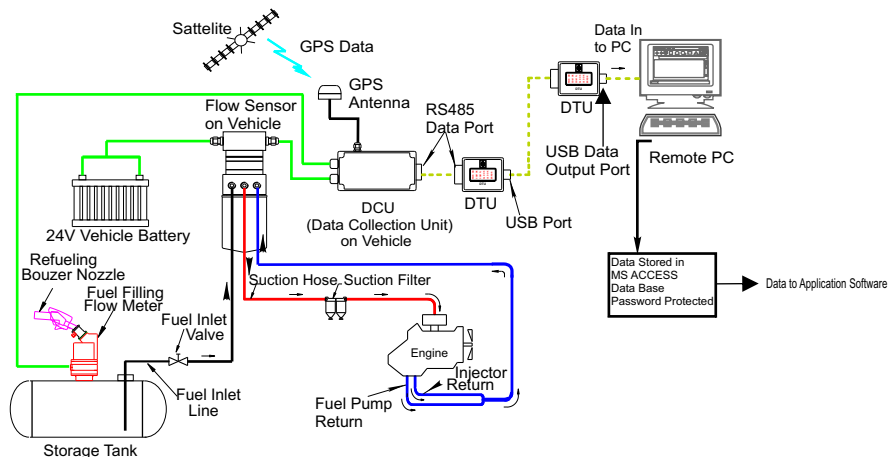

Specifications

1. Fuel Consumption Measurement

- Flow Type - low pressure drop positive displacement
- Accuracy of Measurement - $\pm 0.5\%$ of reading.
- Output - Pulse output to DCU
- Rangeability - 1-500 LPH
- Port - M14x15 / M16x1.5 F
- Mounting - Fabricated and powder coated bracket.
- Hoses - 1/4" and 3/8" High Press. / Temp (optional)
- Filter - 25 micron replacable built in.

2. Data Collection Unit (DCU)

- Type : Low power Micro controller based.
- Inputs : a) Pulse input from Fuel Consumption Sensor
b) Pulse input from Fuel Filling Sensor
- Output : RS 232 serial data output to DCU
- Display : 8x2 Dotmatrix LCD backlight display (optional)
 - a) Filled quantity in litre.
 - b) Consumed quantity in litre.
 - c) No. of data files saved.
- Power Supply : 12 V DC from engine cranking battery.
- Data Retention : Up to 10years without power.

3. Data Transmission Unit (DTU)

- Type - Ultra low power Micro controller based.
- Memory Capacity - 64 MB Flash memory
- DCU Interface - RS 232 for downloaded data.
- Power Supply - 3.6 V DC for DCU while downloading
5 V DC for PC while uploading.
- Data - Up to 10 years without power.
- Housing - Handheld compact weather proof IP54.

4. Engine Run Hours Measurement

- Clock ON/OFF Signal - From Fuel Consumption Sensor Signal with special software algorithm.
- Units of Measurement - Hours and Minutes.
- Accuracy of Measurement - Better than $\pm 0.1\%$ of reading.

5. Fuel Filling Measurement (optional)

- Flow Sensor Type : Low Pressure Drop Positive Displacement.
- Accuracy of Measurement : Better than $\pm 0.5\%$ of reading.
- Output : Pulse output to DCU.
- Rangeability : 5-100 litres/min.
- Input-Port : Filler nozzle interface for dripless filling.
- Housing : On Fuel Storage Tank with flanged connection.
- Filter : Built in 150 micron replacable.